



PRINT SPECIFICATIONS FOR LONGLIFE FOLDING RULERS AND CALIPERS

Especially as advertisement material Long-Life folding rules are a true eye catcher. The original Swiss made metersticks are made out of fiberglas strenghtened polyamid. Hence they are very tough, being extreme weather -and scratch resistant. So they are distinguished from other wooden folding rules by their longevity. With our in-house pad printing technique we can give them a unique look by printing your company's logo or text and lettering on your tools.

Process of Order

1. Contact

For any questions just contact us. We will help you.

2. Order

Once you have chosen the right tool for your needs you can order them. You want your Logo on them? - Not a problem!

3. Logo and Proof of Print

Please, send your logo via e-mail. We will come back to you shortly with a proof of print. We'll prepare your order when you have aproved the preview.

4. Confirmation of Order

We then go ahead and send you the confirmation of your order so you will receive your products as fast as possible.

acceptable Formats:

.eps .ai

Please send your data as a vector graphic, if possible.

Programs such as Adobe Illustrator, Affinity Designer, Corel Draw or similar softwares could be used

these are not suitable:

.pdf .psd .png .gif .jpg

These formats are not suitable, however, could be used which means extra effort on our side.

Resolution:

at least 300 dpi

Then your company's embelm could be printed as sharp as possible. Smaller details won't be lost.

Colors:

Please provide the *pantone* color if the print won't be in standard black or white. So, we can ensure the correct coloration of your logo.

Only in Digital Printing:

Color gradients are very difficult to implement in pad printing. That's why digital printing is used in such cases.

Also a full-cover print could be possible with digital printing - please discuss the details with us.

Also see next page for more information about the printing areas.

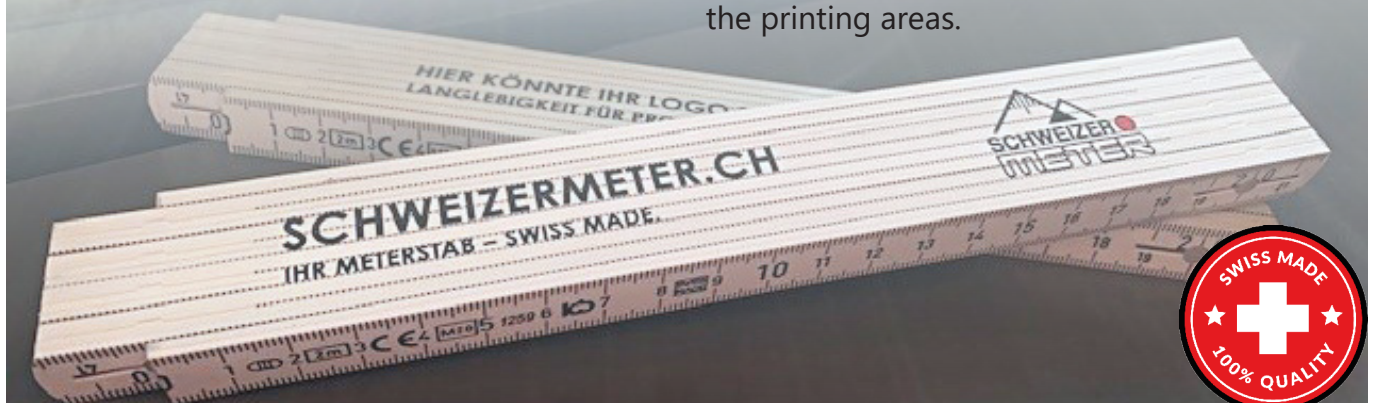



AREA OF PRINTING FOLDING RULES

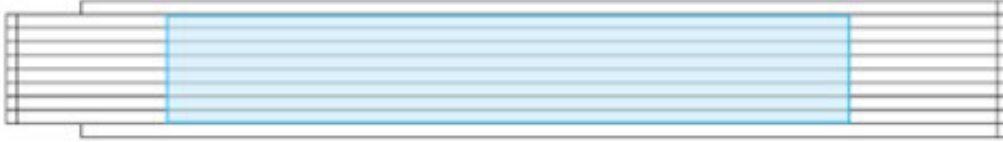

The printing area for LongLife folding rules 2 meter (10 segments) in pad printing is a maximum of **160 x 25 mm / 6.3 x 1 in**

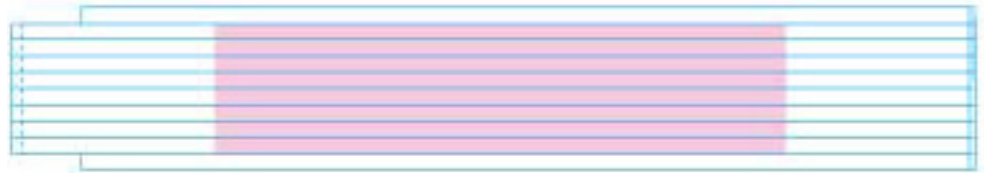

Printing costs

The costs are calculated per color. However, if the print will be on one or both sides doesn't make a difference in price. For the first time printing there will be additional costs for the clichée per color/ motiv. So, if your logo consist of 2 different colors the costs will add up to 2x color and 2x clichée.

In digital printing there will be a difference if the print will be on one or on both sides of the folding ruler. Additional costs are for color matching.

The printing area for LongLife folding rules of only 1 meter (10 segments) in pad printing is a maximum of **82 x 17 mm / 3.2 x 0.7 in**

Proof for Printing:

You can clearly see how the print will look on the folding ruler.

We will send it to you via e-mail.

After your approval and specific order the refined metersticks will get to you as soon as possible.

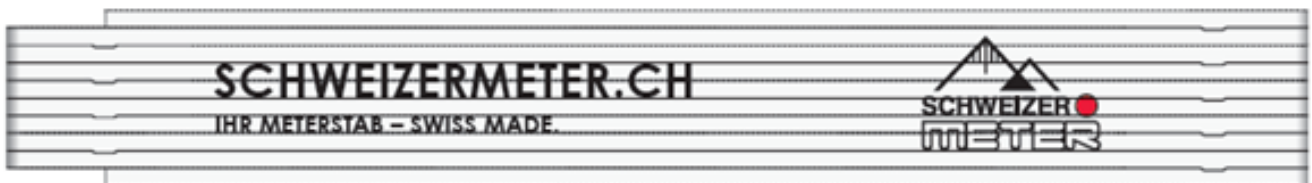

AREA OF PRINTING CALIPERS

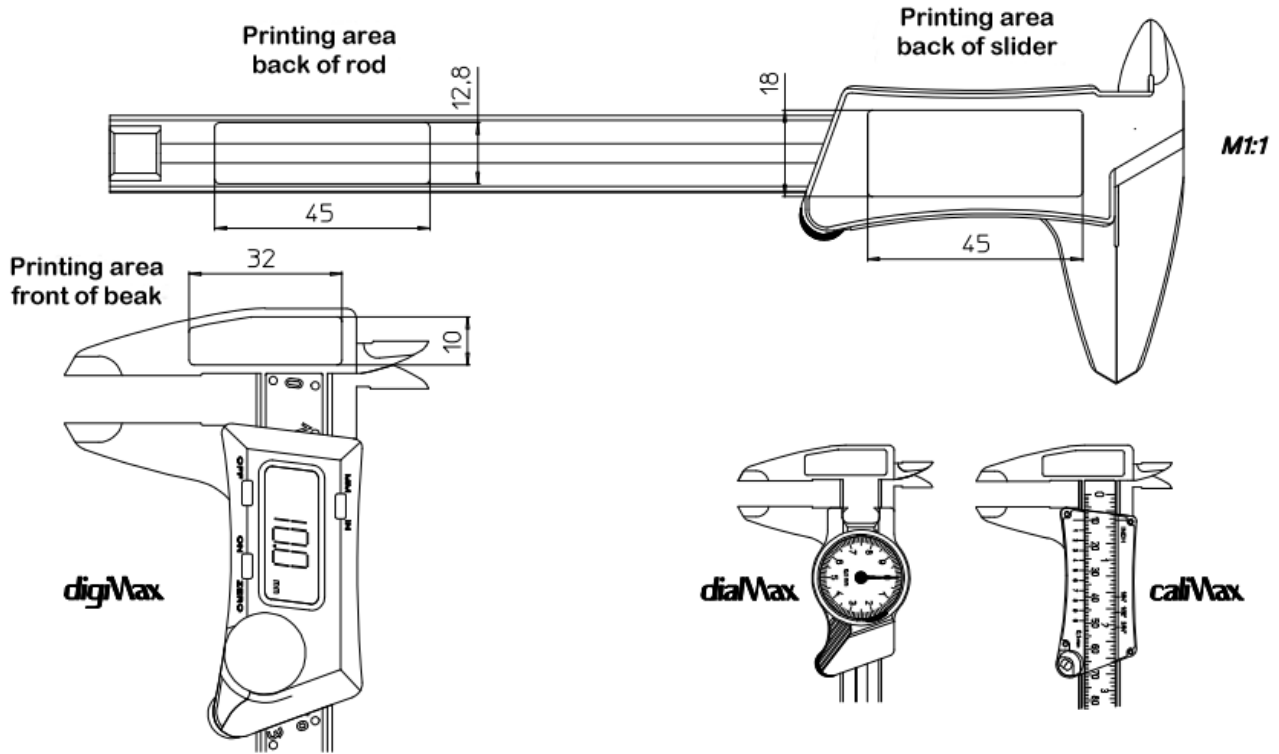

Area for advertising imprint

There are three different printing areas on the calipers *digiMax*, *caliMax* und *dialMax*:

Front Beak

32 x 10 mm / 1.2 x 0.4 in

Back Rod:

45 x 12.8 mm / 1.77 x 0.5 in

Back Slider:

45 x 18 mm / 1.77 x 0.7 in

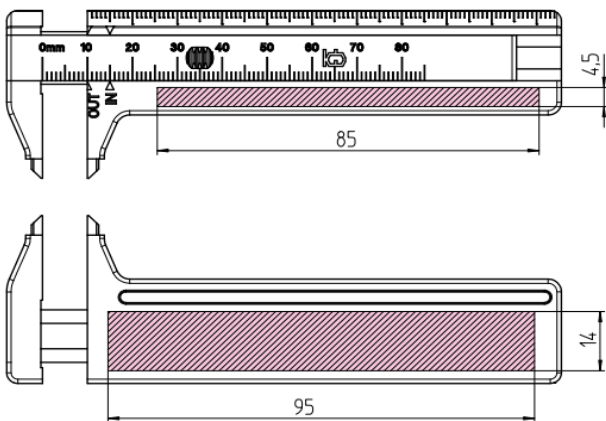

There are two areas for printing on the Pocket-slides:

Front:

75 x 4.4 mm / 2.95 x 0.17 in

Back:

75 x 14 mm / 2.95 x 0.55 in

